

SANITARY PILOT OPERATED PRESSURE REDUCING VALVES P147

DESCRIPTION

The ADCAPure P147 is a series of pilot operated, diaphragm sensing pressure reducing valves.

These regulators, available with spring or dome-loading, are designed for use with clean air, nitrogen, carbon dioxide, oxygen, argon and other gases compatible with the construction materials and valve design. Specifically designed for the high purity gas systems found in the pharmaceutical, cosmetic, fine chemical and food & beverage processes.

MAIN FEATURES

Precise control of downstream pressure from 0,2 to 8 bar.
FDA / USP Class VI compliant seals.
Guided piston and valve stem.
Non-rising adjustment knob.
Completely machined from 316L stainless steel bar stock, no castings or forgings are used.

STANDARD SURFACE FINISH

Internal wetted parts: $\leq 0,51 \mu\text{m Ra} - \text{SF1}$.
External: $\leq 0,76 \mu\text{m Ra} - \text{SF3}$.
Other surface conditions see TIS.GIA – General information ADCAPure.
Ultrasonic cleaning.

OPTIONS: Leakage line connection.
Top cap (adjustment screw with cover).
Gauge connection on body.
Dome-loading.
Bottom cover with drain connection.
Different soft sealings for liquids and gases.

USE: Clean air, nitrogen, carbon dioxide, oxygen, argon and other gases compatible with the construction.
Clean steam (under special request).

AVAILABLE MODELS: P147.

SIZES: 2 1/2" and 3"; DN 65 and DN 80.

REGULATING RANGES: 0,2 – 1,5 bar; 0,3 – 3 bar; 2 – 8 bar.

CONNECTIONS: ASME BPE and DIN clamp ferrules. Others on request.

PACKAGING: Assembling and packaging in a clean room certified according to ISO 14644-1.
The product is end capped and sealed with recyclable thermo-shrinkable plastic film, to avoid contamination.

INSTALLATION: Horizontal installation. See IMI – Installation and maintenance instructions.



CE MARKING – GROUP 2 (PED – European Directive)	
--	--





PN 16	Category
All sizes	1 (CE marked)

LIMITING CONDITIONS *	
-----------------------	--

Maximum allowable pressure	16 bar
Maximum upstream pressure	16 bar
Maximum downstream pressure	8 bar
Minimum downstream pressure	0,2 bar
Maximum operating temperature	150 °C

* Other limits on request. Maximum operating conditions may be limited by the valve end connections due to normative restrictions.

FLOW RATE COEFFICIENTS (m ³ /h)				
SIZE	BPE		DIN	
	2 1/2"	3"	DN 65	DN 80
Kvs	41	46	41	46

OPTIONS				
LEAKAGE LINE CONNECTION	DOME-LOADING	TOP CAP	GAUGE CONNECTION	BOTTOM COVER WITH DRAIN CONNECTION
				

DIMENSIONS

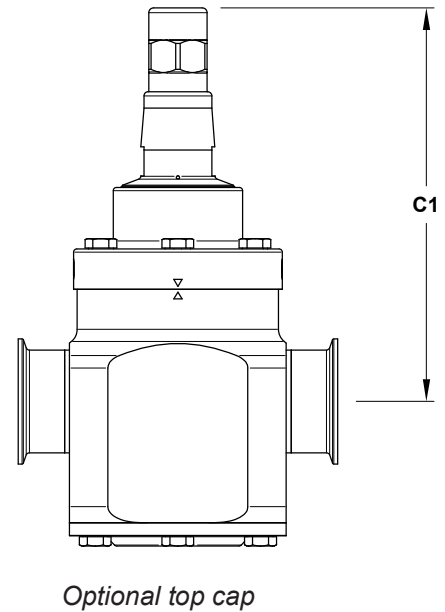
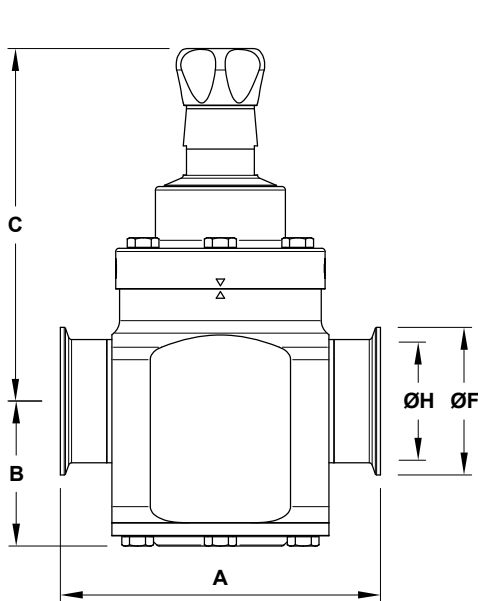

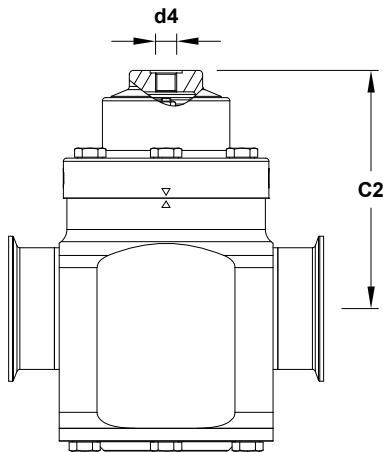

Optional dome-loading

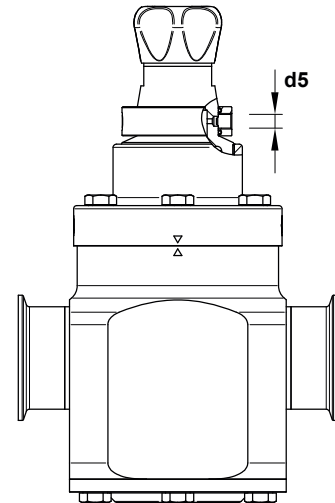

Optional leakage line connection

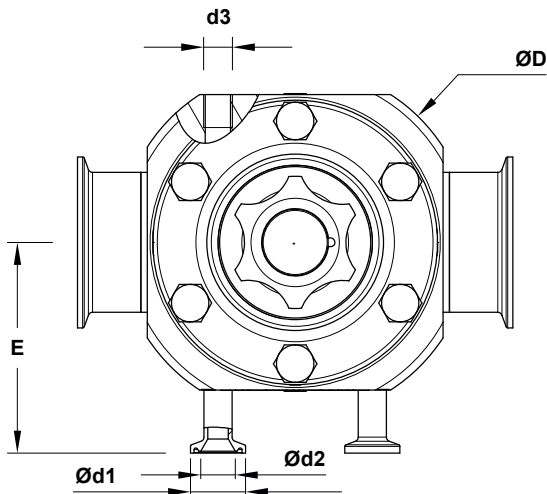

Optional gauge connection

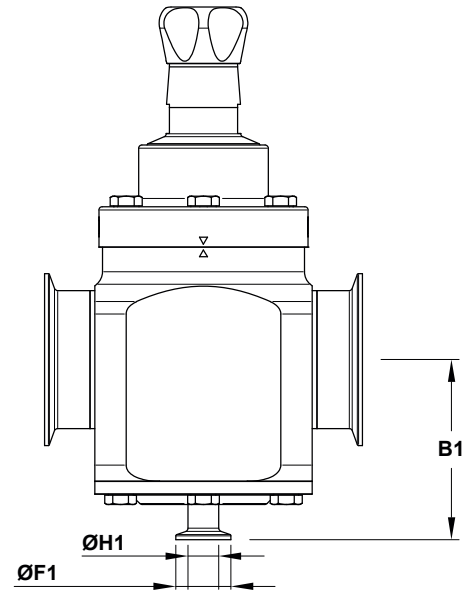

Optional bottom cover with drain connection

DIMENSIONS – ASME BPE (mm)

SIZE	A	B	B1	C	C1	C2	ØD	Ød1	Ød2	d3	d4	d5	E	ØF	ØF1	ØH	ØH1	WGT. (kg) *
2 1/2"	197	89	111	218	243	149	160	25	15,75	1/4"	1/4"	1/8"	95,5	77,4	25	60,2	15,75	17,1
3"	197	89	111	218	243	149	160	25	15,75	1/4"	1/4"	1/8"	95,5	90,9	25	72,9	15,75	17,3

* Valves with nylon adjustment knob weigh 0,3 kg less.

DIMENSIONS – DIN (mm)

SIZE	A	B	B1	C	C1	C2	ØD	Ød1	Ød2	d3	d4	d5	E	ØF	ØF1	ØH	ØH1	WGT. (kg) *
DN 65	196	89	111	218	243	149	160	25	15,75	1/4"	1/4"	1/8"	95,5	91	34	66	16	17,3
DN 80	196	89	111	218	243	149	165	25	15,75	1/4"	1/4"	1/8"	95,5	106	34	81	16	17,8

* Valves with nylon adjustment knob weigh 0,3 kg less.

Remark: Clamp ferrules according to DIN 32676-A.

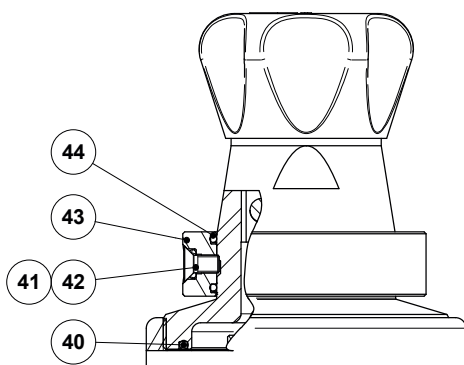
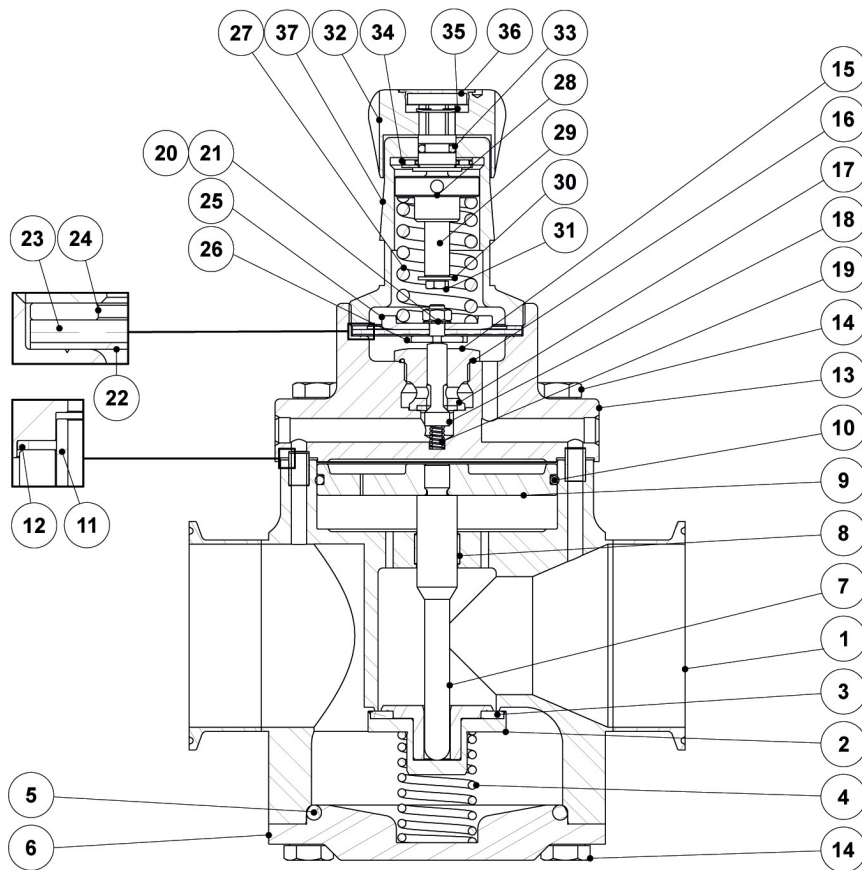

Optional leakage line connection

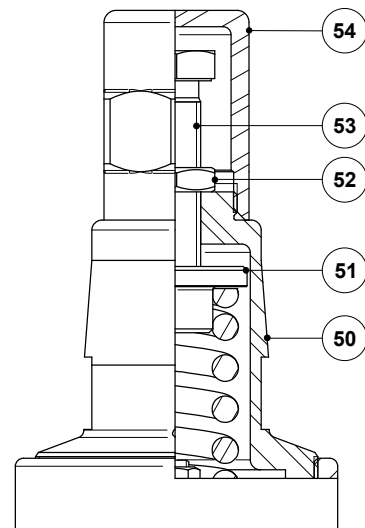

Optional top cap

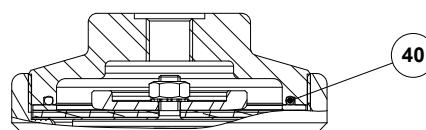

Optional dome-loading

MATERIALS

POS. N°	DESIGNATION	MATERIAL
1	Valve body	AISI 316L / 1.4404
2	* Main valve plug	AISI 316L / 1.4404
3	* Main valve seal	** EPDM; PTFE
4	* Main valve spring	AISI 316 / 1.4401
5	* O-ring	** EPDM
6	Bottom cover	AISI 316L / 1.4404
7	* Main valve stem	AISI 316L / 1.4404
8	* Plain bearing	** PTFE
9	Piston	AISI 316L / 1.4404
10	* O-ring	** EPDM
11	Positioning tube	AISI 316L / 1.4404
12	Gasket	** PTFE
13	Pilot valve body	AISI 316L / 1.4404
14	Bolts	Stainless steel A2-70
15	* Pilot valve seat	AISI 316L / 1.4404
16	* O-ring	** EPDM
17	* Pilot valve seal	** EPDM; PTFE
18	* Pilot valve plug	AISI 316L / 1.4404
19	* Valve spring	AISI 316 / 1.4401 electropolished
20	* Washer	Stainless steel A2
21	* Nut	Stainless steel A2-70
22	* Lower diaphragm	PTFE (Gylon)
23	* Upper diaphragm	EPDM
24	* Washer	AISI 304 / 1.4301
25	* Plate	AISI 316 / 1.4401
26	Nut	Stainless steel A2-70
27	* Adjustment spring	AISI 302 / 1.4300
28	* Spring guide	AISI 316 / 1.4401
29	Adjustment screw	Brass
30	Washer	Stainless steel A2
31	Bolt	Stainless steel A2-70
32	Adjustment knob	AISI 316L / 1.4404; Nylon
33	O-ring	NBR
34	Bearing	Corrosion resistant steel
35	Shaft ring	Stainless steel
36	Cover nut	Plastic
37	Cover	AISI 316L / 1.4404
40	* O-ring	EPDM
41	Bolt	AISI 304 / 1.4301
42	O-ring	FPM
43	Leakage line ring	AISI 316 / 1.4401
44	O-ring	NBR
50	Cover	AISI 316L / 1.4404
51	Spring guide	Brass
52	Lock nut	Stainless steel A2-70
53	Adjustment screw	Stainless steel A2-70
54	Top cap	AISI 316L / 1.4404

* Available spare parts. ** Others on request.

Remarks: FDA / USP Class VI seals certificate on request.

All valves have a serial number. In case of non-standard valves, this number must be supplied if spare parts are ordered.

ORDERING CODES P147												
Valve model	P47	1	6	E	M	I	X	X	X	DI	65	E
P147 – AISI 316L / 1.4404 pilot operated pressure reducing valve	P47											
Regulating range												
0,2 to 1,5 bar		1										
0,3 to 3 bar		2										
2 to 8 bar		3										
0,2 to 8 bar (dome loading) a)		A										
Flow rate coefficient												
Kvs 41			6									
Kvs 46			7									
Diaphragm												
PTFE (Gylon)					T							
EPDM (non-standard)					E							
Valve sealing												
Metal to metal (non-standard)					M							
EPDM					E							
PTFE					T							
Adjustment knob, top cap and leakage line connection												
Stainless steel adjustment knob						I						
Stainless steel adjustment knob with leakage line connection – ISO 228 G 1/8"						L						
Stainless steel adjustment knob with leakage line connection – ISO 228 G 1/8" NPT						Q						
Nylon adjustment knob						P						
Nylon adjustment knob with leakage line connection – ISO 228 G 1/8"						N						
Nylon adjustment knob with leakage line connection – ISO 228 G 1/8" NPT						M						
Top cap (adjustment screw with cover)						T						
Top cap (adjustment screw with cover) with leakage line connection – ISO 228 G 1/8"						U						
Top cap (adjustment screw with cover) with leakage line connection – ISO 228 G 1/8" NPT						V						
Dome-loading – ISO 228 G 1/4" b)						X						
Dome-loading – 1/4" NPT b)						C						
Gauge connections												
Without gauge connections							X					
Tri-clamp gauge conn. left side (relative to flow direction) – upstream pressure – 1 connection							7					
Tri-clamp gauge conn. right side (relative to flow direction) – upstream pressure – 1 connection							6					
Tri-clamp gauge conn. left side (relative to flow direction) – upstream & downstream press. – 2 connections							9					
Tri-clamp gauge conn. right side (relative to flow direction) – upstream & downstream press. – 2 connections							8					
Tri-clamp gauge conn. both sides – upstream pressure – 2 connections							5					
Threaded gauge conn. left side (relative to flow direction) – upstream pressure – ISO 228 G 1/4"							4					
Threaded gauge conn. right side (relative to flow direction) – upstream pressure – ISO 228 G 1/4"							3					
Threaded gauge conn. left side (rel. to flow direction) – upstream & downstream press. – 2 conn. – ISO 228 G 1/4"							1					
Threaded gauge conn. right side (rel. to flow direction) – upstream & downstream press. – 2 conn. – ISO 228 G 1/4"							0					
Threaded gauge conn. both sides – upstream pressure – ISO 228 G 1/4"							2					
Threaded gauge conn. left side (relative to flow direction) – upstream pressure – 1/4" NPT							W					
Threaded gauge conn. right side (relative to flow direction) – upstream pressure – 1/4" NPT							Y					
Threaded gauge conn. left side (relative to flow direction) – upstream & downstream press. – 2 conn. – 1/4" NPT							U					
Threaded gauge conn. right side (relative to flow direction) – upstream & downstream press. – 2 conn. – 1/4" NPT							V					
Threaded gauge conn. both sides – upstream pressure – 1/4" NPT							Z					
Surface finish c)												
Standard surface finish								X				
Mirror mechanical polished external surfaces (SF1)									P			
Electropolished internal wetted parts (SF5)										E		
Special features												
None										X		
Degreased for oxygen											O	
Bottom cover with drain connection											D	
Pipe connection												
Clamp ferrule ASME BPE												D
Clamp ferrule DIN (DIN 32676-A)												F
Tube weld (ETO) according to ASME BPE												DI
Tube weld (ETO) according to DIN 11866-A (DIN 11850-2)												FI
Size												
21/2" or DN 65												65
3" or DN 80												80
Special construction / Additional options												
Full description or additional codes have to be added in case of non-standard combination												E

a) The loading control pressure can be up to a maximum of 1,2 bar above the required downstream pressure. b) Mandatory in case of dome-loading. c) Consult TIS.GIA – General information ADCAPure – for further details and other surface finish options.