

SANITARY PRESSURE SUSTAINING VALVES PS163

DESCRIPTION

The ADCAPure PS163 is a series of inline direct acting diaphragm sensing pressure sustaining valves.

These regulators, available with spring or dome-loading, are designed for use with clean steam, compressed air, water and other gases or liquids compatible with the construction materials and valve design.

MAIN FEATURES

- Spring or dome-loading.
- Non-rising adjustment knob.
- Compact inline design with clamped body.
- FDA / USP Class VI compliant seals.
- Completely machined from bar stock material, no castings or forgings are used.

STANDARD SURFACE FINISH

- Internal wetted parts: $\leq 0,51 \mu\text{m Ra} - \text{SF1}$.
- External: $\leq 0,76 \mu\text{m Ra} - \text{SF3}$.
- Other surface conditions see TIS.GIA – General information ADCAPure.
- Ultrasonic cleaning.

- OPTIONS:
- Leakage line connection.
 - Dome-loading.
 - Top cap (adjustment screw with cover).
 - Gauge connection on body.
 - Bottom cover with drain connection.
 - Different soft sealings for liquids and gases.
 - Degreased for oxygen application.

- USE:
- Clean steam, compressed air, water and other gases and liquids compatible with the construction.

- AVAILABLE MODELS:
- PS163.

- SIZES:
- 1/2" to 2"; DN 15 to DN 50.

- REGULATING RANGES:
- 0,8 to 1,5 bar; 1 to 3 bar; 1,5 to 8 bar.

- CONNECTIONS:
- ASME BPE, DIN and ISO clamp ferrules or tube weld (ETO) ends.
 - Others on request.

- PACKAGING:
- Assembling and packaging in a clean room certified according to ISO 14644-1.
 - The product is end capped and sealed with recyclable thermo-shrinkable plastic film, to avoid contamination.

- INSTALLATION:
- Horizontal installation. See IMI – Installation and maintenance instructions.

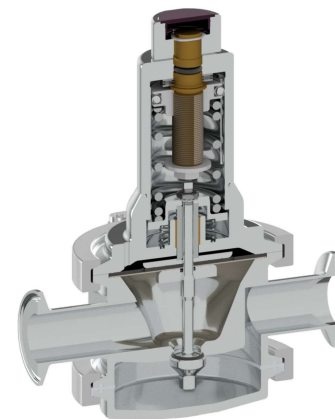

CE MARKING – GROUP 2 (PED – European Directive)	
PN 10	Category
1/2" to 2" – DN 15 to 50	SEP

LIMITING CONDITIONS *	
Maximum allowable pressure	10 bar
Maximum upstream pressure	8 bar
Minimum upstream pressure	0,8 bar
Maximum operating temperature **	180 °C





* Other limits on request. Maximum operating conditions may be limited by the valve end connections due to normative restrictions.

** See "Ordering Codes" table for restrictions.

FLOW RATE COEFFICIENTS (m³/h)

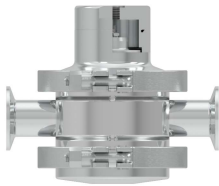
SIZE	ASME BPE					DIN						ISO				
	1/2"	3/4"	1"	1 1/2"	2"	DN 15	DN 20	DN 25	DN 32	DN 40	DN 50	DN 15	DN 20	DN 25	DN 32	DN 40
Kvs	1,3	3	4,2	7	13	2,1	3	4,2	4,2	7	13	2,1	4,2	4,2	7	7

OPTIONS

LEAKAGE LINE CONNECTION	DOME-LOADING	TOP CAP	GAUGE CONNECTION	BOTTOM COVER WITH DRAIN CONNECTION
				

DIMENSIONS

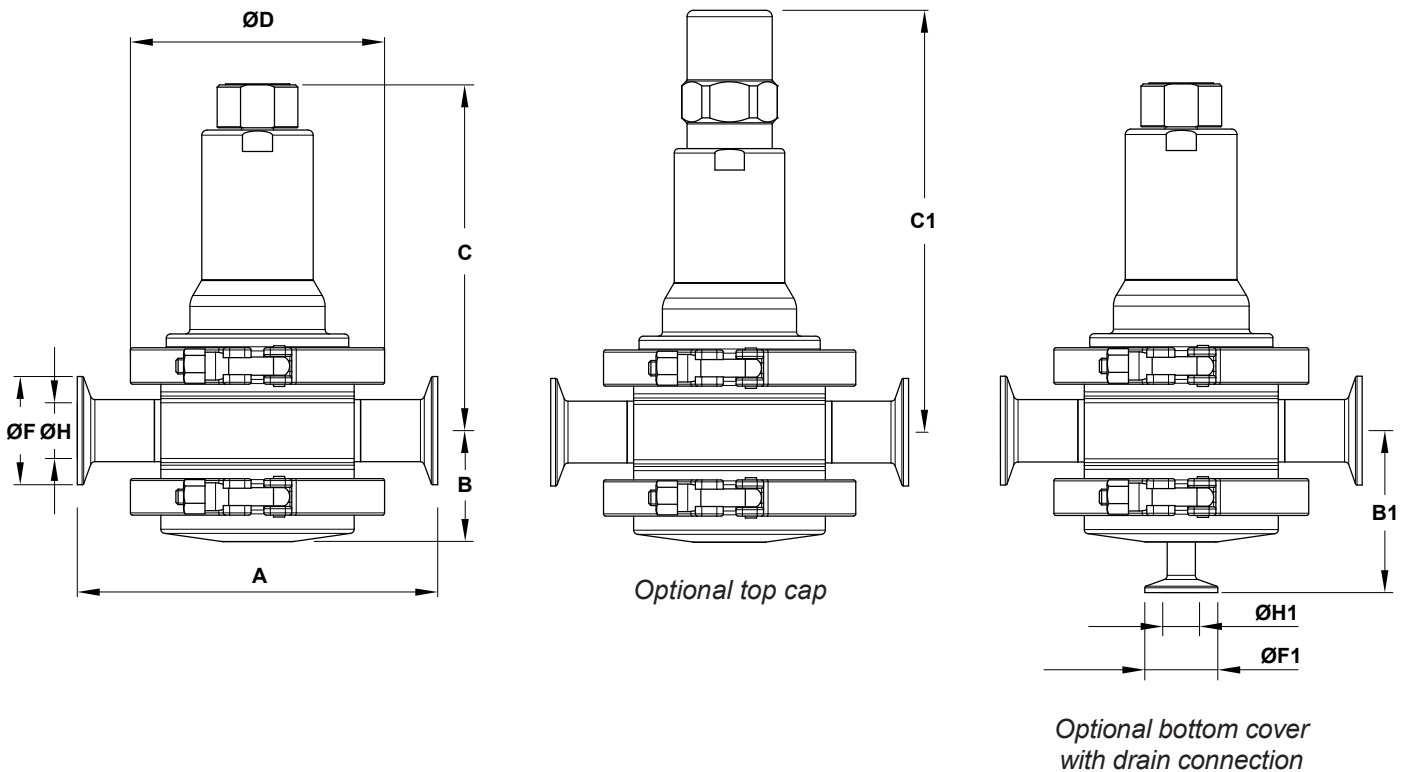

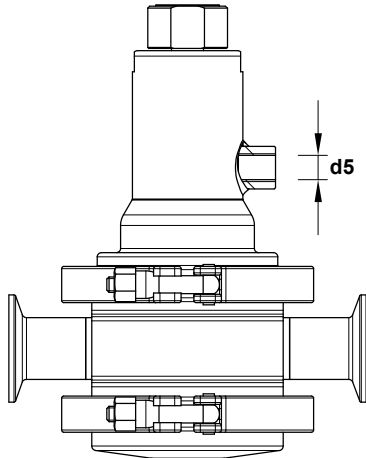

Optional leakage
line connection

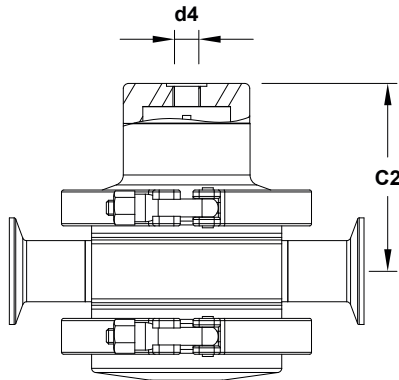

Optional dome loading

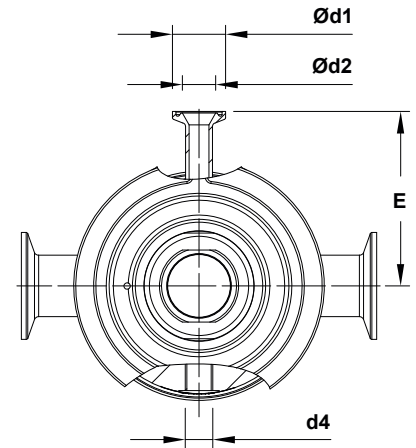

Optional gauge connection

DIMENSIONS – ASME BPE (mm)

SIZE	A	B	B1	C	C1	C2	ØD	Ød1	Ød2	d3	d4	d5	E	ØF	ØF1	ØH	ØH1	WGT. (kg)
1/2"	153	47	70	156	193	84	119	25	15,75	1/4"	1/4"	1/4"	83	25	25	9,4	9,4	5
3/4"	153	51	74	160	197	88	119	25	15,75	1/4"	1/4"	1/4"	83	25	25	15,8	9,4	5,6
1"	153	54	77	163	200	91	119	25	15,75	1/4"	1/4"	1/4"	83	50,4	25	22,1	9,4	5,7
1 1/2"	170	71	95	204	247	124	134	25	15,75	1/4"	1/4"	1/4"	96	50,4	25	34,8	9,4	9,8
2"	170	74	99	207	244	127	134	25	15,75	1/4"	1/4"	1/4"	96	63,9	25	47,5	9,4	9,8

DIMENSIONS – DIN (mm)

SIZE	A	B	B1	C	C1	C2	ØD	Ød1	Ød2	d3	d4	d5	E	ØF	ØF1	ØH	ØH1	WGT. (kg)
DN 15	153	51	74	160	197	88	119	25	15,75	1/4"	1/4"	1/4"	83	34	34	16	10	5,6
DN 20	153	49	72	158	195	86	119	25	15,75	1/4"	1/4"	1/4"	83	34	34	20	10	5,3
DN 25	168	52	75	161	198	89	119	25	15,75	1/4"	1/4"	1/4"	83	50,5	34	26	10	5,6
DN 32	168	54	77	163	200	91	119	25	15,75	1/4"	1/4"	1/4"	83	50,5	34	32	10	5,8
DN 40	185	70	94	202	239	122	134	25	15,75	1/4"	1/4"	1/4"	96	50,5	34	38	10	9,5
DN 50	185	74	98	206	243	126	134	25	15,75	1/4"	1/4"	1/4"	96	64	34	50	10	9,8

Remarks: Clamp ferrules according to DIN 32676-A. Tube weld (ETO) according to DIN 11866-A (DIN 11850-2).

DIMENSIONS – ISO (mm)

SIZE	A	B	B1	C	C1	C2	ØD	Ød1	Ød2	d3	d4	d5	E	ØF	ØF1	ØH	ØH1	WGT. (kg)
DN 15	168	50	73	159	196	87	119	25	15,75	1/4"	1/4"	1/4"	83	50,5	25	18,1	10,3	5,4
DN 20	168	53	76	162	199	90	119	25	15,75	1/4"	1/4"	1/4"	83	50,5	25	23,7	10,3	5,6
DN 25	168	55	78	164	201	92	119	25	15,75	1/4"	1/4"	1/4"	83	50,5	25	29,7	10,3	6
DN 32	185	69	93	202	239	122	134	25	15,75	1/4"	1/4"	1/4"	96	64	25	38,4	10,3	9,6
DN 40	185	76	100	206	243	126	134	25	15,75	1/4"	1/4"	1/4"	96	64	25	44,3	10,3	10

Remarks: Clamp ferrules according to DIN 32676-B. Tube weld (ETO) according to DIN 11866-B (ISO 1127).

MATERIALS

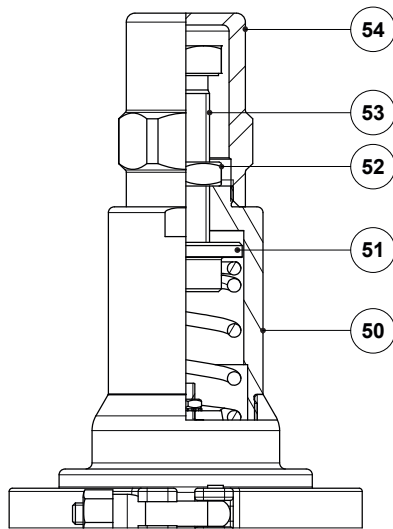
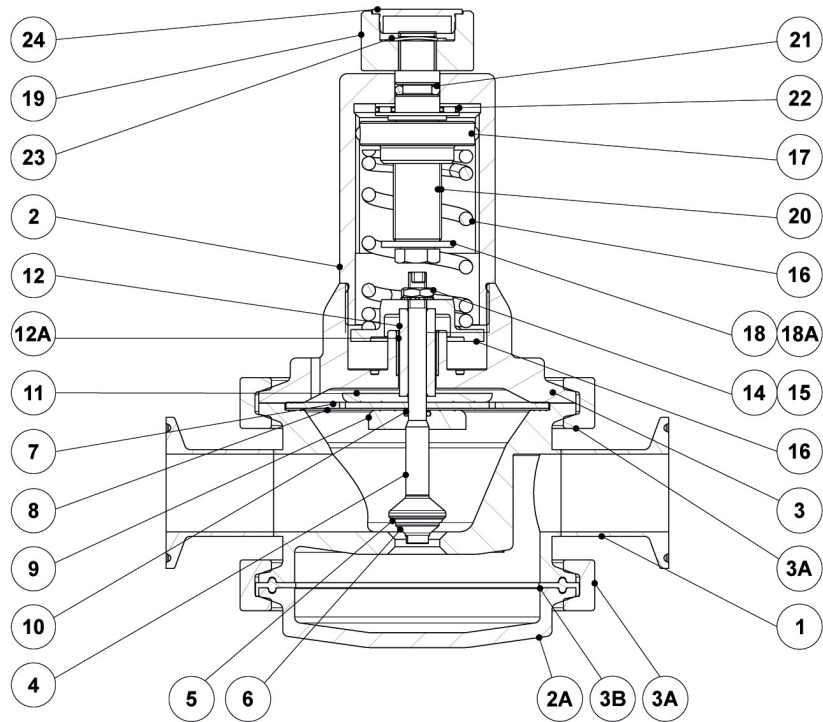

Optional top cap

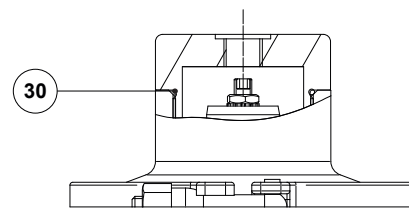

Optional dome-loading

MATERIALS

POS. N°	DESIGNATION	MATERIAL
1	Valve body	AISI 316L / 1.4404
2	Cover	AISI 316L / 1.4404
2A	Bottom cover	AISI 316L / 1.4404
3	Intermediate flange	AISI 316L / 1.4404
3A	Clamp	AISI 316 / 1.4401
3B	* Gasket	** PTFE/FPM Envelope
4	* Valve stem	AISI 316L / 1.4404
5	* Valve seal	** EPDM; PTFE; FPM
6	* Valve plug	AISI 316L / 1.4404
7	* Upper diaphragm	EPDM
8	* Lower diaphragm	PTFE (Gylon)
9	Lower diaphragm plate	AISI 316L / 1.4404
10	* O-ring	** EPDM; PTFE; FPM
11	Upper diaphragm plate	AISI 316L / 1.4404
12	Stem guide	AISI 316L / 1.4404
12A	Plain bearing	Bronze
13	Spring plate	AISI 316L / 1.4404
14	Nut	Stainless steel A2-70
15	* Washer	Stainless steel A2
16	* Adjustment spring	AISI 302 / 1.4300
17	Top spring plate	AISI 316L / 1.4404
18	Washer	Stainless steel A2
18A	Bolt	Stainless steel A2-70
19	Adjustment knob	AISI 316L / 1.4404
20	Adjustment screw	Brass
21	O-ring	NBR
22	Bearing	Corrosion resistant steel
23	Shaft ring	Stainless steel
24	Cover nut	Plastic
30	* O-ring	EPDM
50	Cover	AISI 316L / 1.4404
51	Spring guide	Brass
52	Lock nut	Stainless steel A2-70
53	Adjustment screw	Stainless steel A2-70
54	Top cap	AISI 316L / 1.4404

* Available spare parts. ** Others on request.

Remarks: FDA / USP Class VI seals certificate on request.

All valves have a serial number. In case of non-standard valves, this number must be supplied if spare parts are ordered.



ORDERING CODES PS163

Valve model	PS63	1	4	1	T	M	I	X	X	X	DI	15	E
PS163 – AISI 316L / 1.4404 diaphragm sensing press. sustaining valve without drain	PS63												
PS163 – AISI 316L / 1.4404 diaphragm sensing press. sustaining valve with drain	PS6D												
Valve series													
Series 1		1											
Regulating range													
0,8 to 1,5 bar			4										
1 to 3 bar			5										
1,5 to 8 bar			6										
0,8 to 8 bar (dome-loading) a)			A										
Flow rate coefficient													
Kvs 1,3 (only applicable to ASME BPE 1/2" size)				1									
Kvs 2,1 (applicable to sizes DIN DN 15 and ISO DN 15)				2									
Kvs 3 (applicable to sizes ASME BPE 3/4" and DIN DN 20)				3									
Kvs 4,2 (applicable to sizes ASME BPE 1", DIN DN 25 to DN 32 and ISO DN 20 to DN 25)				4									
Kvs 7 (applicable to sizes ASME BPE 1 1/2", DIN DN 40 and ISO DN 32 to DN 40)				6									
Kvs 13 (applicable to sizes ASME BPE 2" and DIN DN 50)				8									
Diaphragm													
PTFE (Gylon)					T								
EPDM (non-standard) – Tmax 150 °C					E								
Valve sealing b)													
Metal to metal (non-standard, except in ASME BPE 1/2" size)						M							
EPDM – Tmax 150 °C (180 °C with steam and hot water)						E							
PTFE						T							
FPM / Viton (USP Class VI on request)						V							
Adjustment knob, top cap and leakage line connection													
Stainless steel adjustment knob							I						
Top cap (adjustment screw with cover)							T						
Stainless steel adjustment knob w/ ISO 228 G 1/4" leakage line connection							L						
Stainless steel adjustment knob w/ 1/4" NPT leakage line connection							M						
Top cap (adjustment screw with cover) w/ ISO 228 G 1/4" leakage line connection							U						
Top cap (adjustment screw with cover) w/ 1/4" NPT leakage line connection							V						
Dome-loading – ISO 228 G 1/4" c)							X						
Dome-loading – 1/4" NPT c)							C						
Gauge connections													
Without gauge connections								X					
Tri-clamp gauge connection on the left side (relative to flow direction) – downstream pressure								7					
Tri-clamp gauge connection on the right side (relative to flow direction) – downstream pressure								6					
Tri-clamp gauge connections on both sides – downstream pressure								5					
Threaded gauge connection on the left side (relative to flow direction) – downstream pressure – ISO 228 G 1/4"								4					
Threaded gauge connection on the right side (relative to flow direction) – downstream pressure – ISO 228 G 1/4"								3					
Threaded gauge connections on both sides – downstream pressure – ISO 228 G 1/4"								2					
Threaded gauge connection on the left side (relative to flow direction) – downstream pressure – 1/4" NPT								W					
Threaded gauge connection on the right side (relative to flow direction) – downstream pressure – 1/4" NPT								Y					
Threaded gauge connections on both sides – downstream pressure – 1/4" NPT								Z					
Surface finish d)													
Standard surface finish									X				
Mirror mechanical polished external surfaces (SF1)									P				
Electropolished internal wetted parts (SF5)									E				
Special features													
None										X			
Degreased for oxygen										O			
Pipe connection													
Clamp ferrule ASME BPE												D	
Clamp ferrule DIN (DIN 32676-A)												F	
Clamp ferrule ISO (DIN 32676-B)												E	
Tube weld (ETO) according to ASME BPE												DI	
Tube weld (ETO) according to DIN 11866-A (DIN 11850-2)												FI	
Tube weld (ETO) according to DIN 11866-B (ISO 1127)												EI	
Size													
1/2" or DN 15												15	
3/4" or DN 20												20	
1" or DN 25												25	
DN 32												32	
1 1/2" or DN 40												40	
2" or DN 50												50	
Special construction / Additional options													
Full description or additional codes have to be added in case of a non-standard combination													E

a) The loading control pressure can be up to a maximum of 0,2 bar above the required upstream pressure. b) ASME BPE 1/2" size is only available with metal to metal sealing. c) Mandatory in case of dome-loading. d) Consult TIS.GIA – General information ADCAPure – for further details and other surface finish options.