

SANITARY PRESSURE SUSTAINING VALVES PS173

DESCRIPTION

The ADCAPure PS173 is a series of inline direct acting, diaphragm sensing pressure sustaining valves. These spring-loading loaded regulators are designed for use with clean steam, compressed air, water and other gases or liquids compatible with the construction materials and valve design.

MAIN FEATURES

Compact inline design.
Non-rising adjustment knob.
FDA / USP Class VI compliant seals.
Completely machined from bar stock material, no castings or forgings are used on the standard version.

STANDARD SURFACE FINISH

Internal wetted parts: $\leq 0,51 \mu\text{m Ra} - \text{SF1}$.
External: $\leq 0,76 \mu\text{m Ra} - \text{SF3}$.
Other surface conditions see TIS.GIA – General information ADCAPure.
Ultrasonic cleaning.

OPTIONS: Leakage line connection.
Top cap (adjustment screw with cover).
Gauge connection on body.
Bottom cover with drain connection.
Different soft sealings for liquids and gases.

USE: Clean steam, compressed air, water and other gases and liquids compatible with the construction.

AVAILABLE MODELS: PS173.

SIZES: 1 1/2" and 2"; DN 32 to DN 50.

REGULATING RANGES: 0,8 to 1,5 bar; 1 to 3 bar; 1,5 to 8 bar.

CONNECTIONS: ASME BPE, DIN and ISO clamp ferrules or tube weld (ETO) ends. Others on request.

PACKAGING: Assembling and packaging in a clean room certified according to ISO 14644-1.
The product is end capped and sealed with recyclable thermo-shrinkable plastic film, to avoid contamination.

INSTALLATION: Horizontal installation.
See IMI – Installation and maintenance instructions.



CE MARKING – GROUP 2 (PED – European Directive)

PN 10	Category
1 1/2" and 2" – DN 32 to 50	SEP





LIMITING CONDITIONS *

Maximum allowable pressure	10 bar
Maximum upstream pressure	8 bar
Minimum upstream pressure	0,8 bar
Maximum operating temperature **	180 °C

* Other limits on request. Maximum operating conditions may be limited by the valve end connections due to normative restrictions.

** See "Ordering Codes" table for restrictions.

FLOW RATES COEFFICIENTS (m³/h)						
SIZE	ASME BPE		DIN		ISO	
	1 1/2"	2"	DN 40	DN 50	DN 32	DN 40
Kvs	5,5	8,5	5,5	8,5	5,5	8,5

OPTIONS			
LEAKAGE LINE CONNECTION	TOP CAP	GAUGE CONNECTION	BOTTOM COVER WITH DRAIN CONNECTION
			

DIMENSIONS

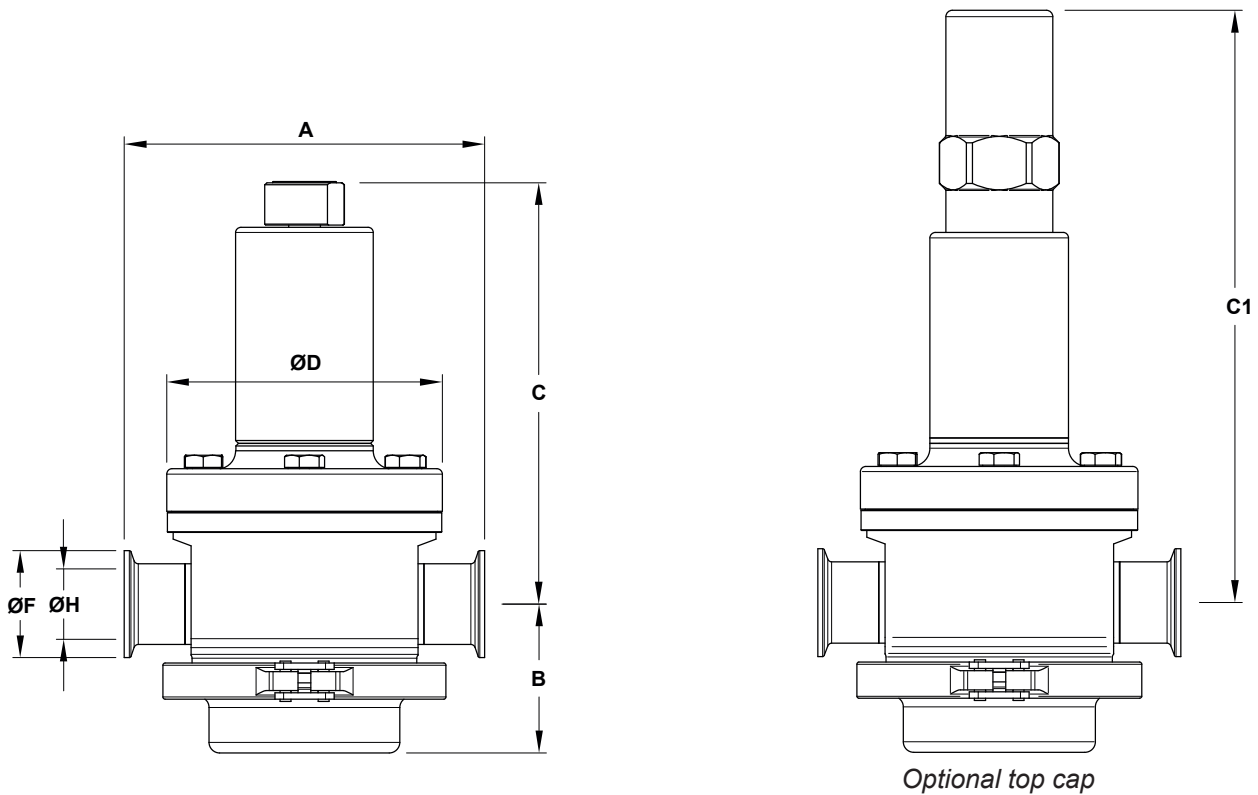

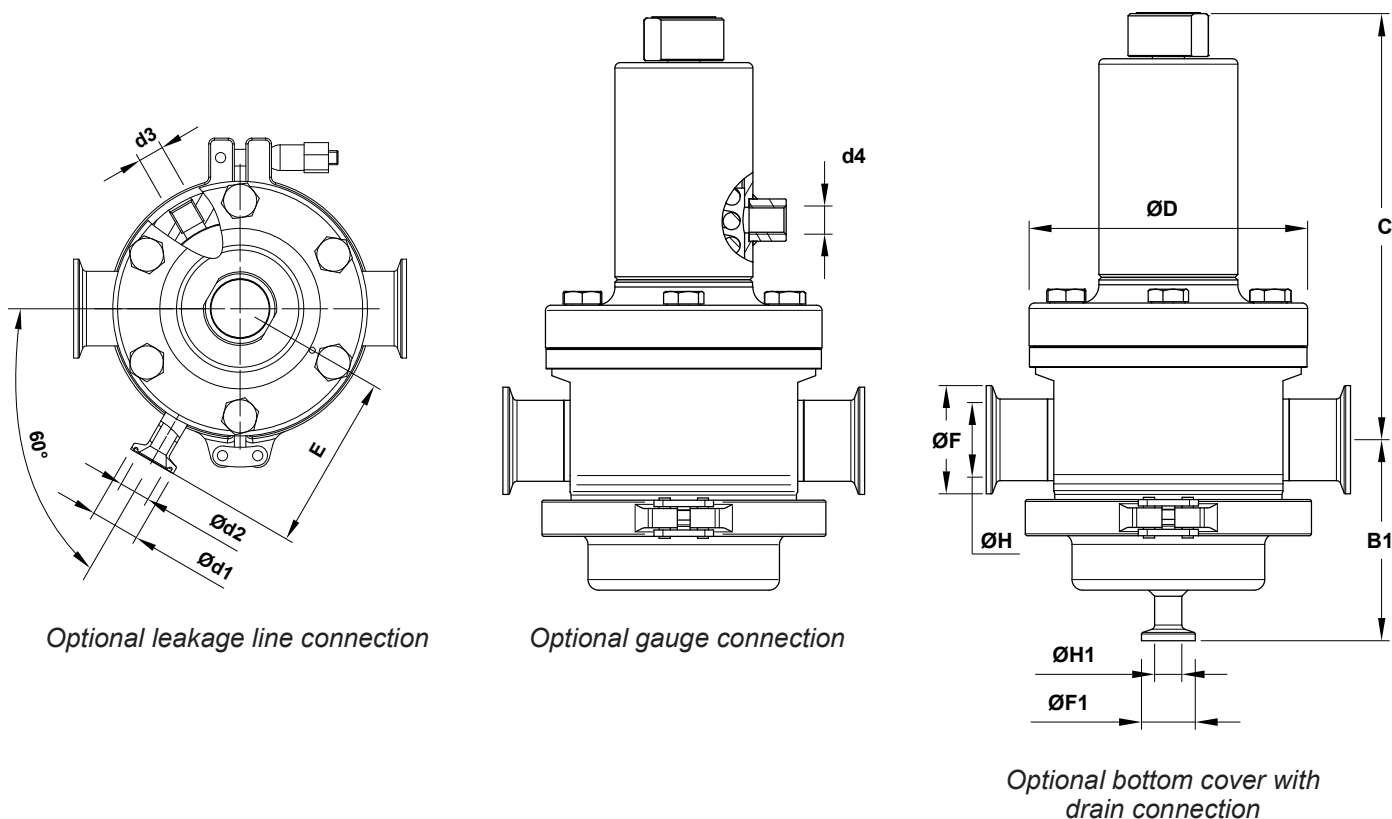

DIMENSIONS – ASME BPE (mm)

SIZE	A	B	B1	C	C1	ØD	Ød1	Ød2	d3	d4	E	ØF	ØH	ØF1	ØH1	WGT. (kg)
1 1/2"	170	70	94	199	277	130	25	15,75	1/4"	1/4"	90	50,4	34,8	25	9,4	8,6
2"	170	76	99	205	283	130	25	15,75	1/4"	1/4"	90	63,9	47,5	25	9,4	8,9

DIMENSIONS – DIN (mm)

SIZE	A	B	B1	C	C1	ØD	Ød1	Ød2	d3	d4	E	ØF	ØH	ØF1	ØH1	WGT. (kg)
DN 40	170	70	94	199	277	130	25	15,75	1/4"	1/4"	90	50,5	38	34	10	8,6
DN 50	170	76	99	205	283	130	25	15,75	1/4"	1/4"	90	64	50	34	10	8,9

Remarks: Clamp ferrules according to DIN 32676-A. Tube weld (ETO) according to DIN 11866-A (DIN 11850-2).

DIMENSIONS – ISO (mm)

SIZE	A	B	B1	C	C1	ØD	Ød1	Ød2	d3	d4	E	ØF	ØH	ØF1	ØH1	WGT. (kg)
DN 32	170	70	93	199	277	130	25	15,75	1/4"	1/4"	90	64	38,4	25	10,3	8,6
DN 40	170	76	99	205	283	130	25	15,75	1/4"	1/4"	90	64	44,3	25	10,3	9,2

Remarks: Clamp ferrules according to DIN 32676-B. Tube weld (ETO) according to DIN 11866-B (ISO 1127).

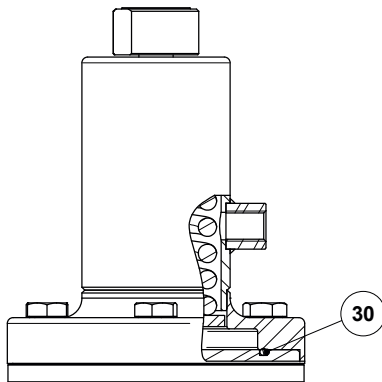
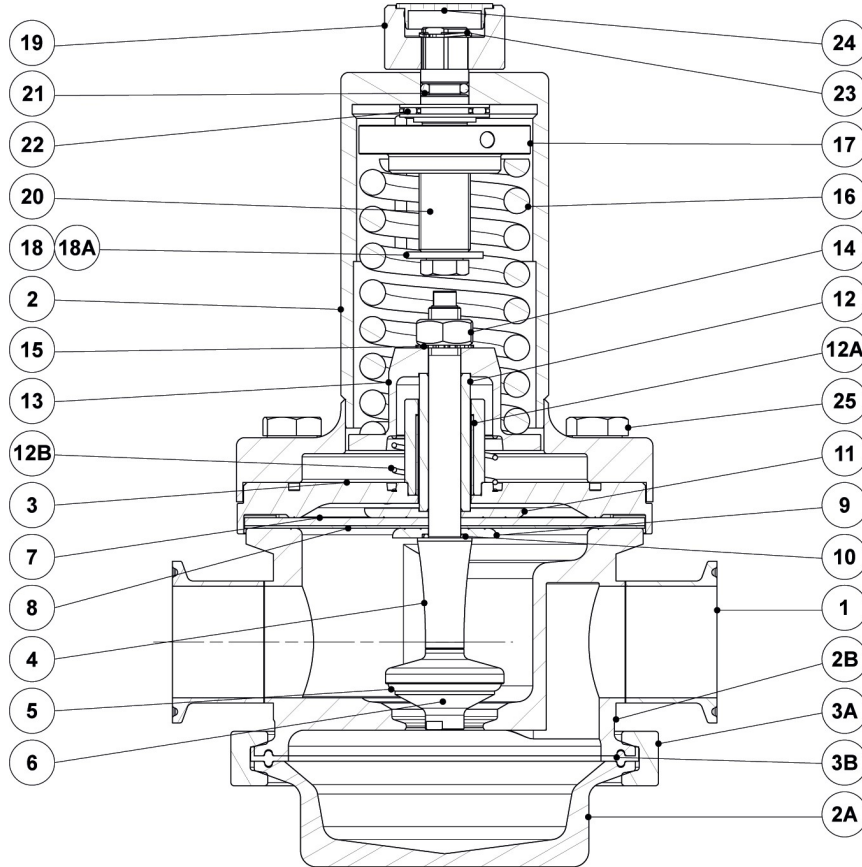

Optional leakage line connection

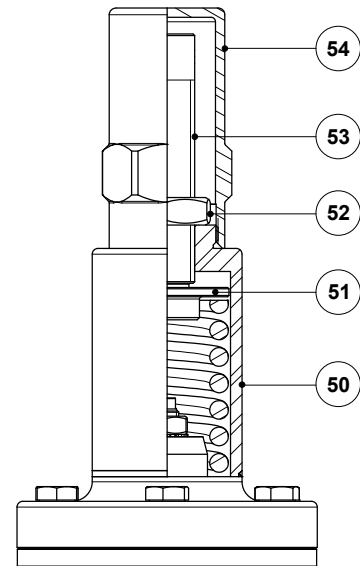

Optional top cap

MATERIALS

POS. N°	DESIGNATION	MATERIAL
1	Valve body	AISI 316L / 1.4404
2	Cover	AISI 316L / 1.4404
2A	Bottom cover	AISI 316L / 1.4404
3	Intermediate flange	AISI 316L / 1.4404
3A	Safety clamp	AISI 316 / 1.4401
3B	* Gasket	** PTFE/FPM Envelope
4	* Valve stem	AISI 316L / 1.4404
5	* Valve seal	** EPDM; PTFE; FPM
6	* Valve plug	AISI 316L / 1.4404
7	* Upper diaphragm	EPDM
8	* Lower diaphragm	PTFE (Gylon)
9	Lower diaphragm plate	AISI 316L / 1.4404
10	* O-ring	** EPDM; PTFE; FPM
11	Upper diaphragm plate	AISI 316L / 1.4404
12	Stem guide	AISI 316L / 1.4404
12A	Plain bearing	Bronze
12B	Spring	AISI 302 / 1.4300
13	Spring plate	AISI 316L / 1.4404
14	Nut	Stainless steel A2-70
15	* Washer	Stainless steel A2
16	* Adjustment spring	AISI 302 / 1.4300
17	Top spring plate	AISI 316L / 1.4404
18	Washer	Stainless steel A2
18A	Bolt	Stainless steel A2-70
19	Adjustment knob	AISI 316L / 1.4404
20	Adjustment screw	Brass
21	O-ring	NBR
22	Bearing	Corrosion resistant steel
23	Shaft ring	Stainless steel
24	Cover nut	Plastic
25	Bolts	Stainless steel A2-70
30	* O-ring	EPDM
50	Cover	AISI 316L / 1.4404
51	Spring guide	Brass
52	Lock nut	Stainless steel A2-70
53	Adjustment screw	Stainless steel A2-70
54	Top cap	AISI 316L / 1.4404

* Available spare parts. ** Others on request.

Remarks: FDA / USP Class VI seals certificate on request.

All valves have a serial number. In case of non-standard valves, this number must be supplied if spare parts are ordered.

ORDERING CODES PS173												
Valve model	PS17D	4	4	T	M	I	X	X	X	DI	32	
PS173 – AISI 316L / 1.4404 diaphragm sensing pressure sustaining valve with drain	PS17D											
PS173 – AISI 316L / 1.4404 diaphragm sensing pressure sustaining valve without drain	PS17											
Regulating range												
0,8 to 1,5 bar		4										
1 to 3 bar		5										
1,5 to 8 bar		7										
Flow rate coefficient												
Kvs 5,5		4										
Kvs 8,5		6										
Diaphragm												
PTFE (Gylon)				T								
EPDM (non-standard) – Tmax 150 °C				E								
Valve sealing												
Metal to metal (non-standard)					M							
EPDM – Tmax 150 °C (180 °C with steam and hot water)					E							
PTFE					T							
FPM / Viton (FDA approval only)					V							
Adjustment knob, top cap and leakage line connection												
Stainless steel adjustment knob						I						
Top cap (adjustment screw with cover)						T						
Stainless steel adjustment knob w/ ISO 228 G 1/4" leakage line connection						L						
Stainless steel adjustment knob w/ 1/4" NPT leakage line connection						M						
Top cap (adjustment screw with cover) w/ ISO 228 G 1/4" leakage line connection						U						
Top cap (adjustment screw with cover) w/ 1/4" NPT leakage line connection						V						
Gauge connections												
Without gauge connections									X			
Tri-clamp gauge conn. left side (relative to flow direction) – upstream pressure – 1 connection									7			
Tri-clamp gauge conn. right side (relative to flow direction) – upstream pressure – 1 connection									6			
Tri-clamp gauge conn. left side (relative to flow direction) – upstream & downstream press. – 2 connections									9			
Tri-clamp gauge conn. right side (relative to flow direction) – upstream & downstream press. – 2 connections									8			
Tri-clamp gauge conn. both sides – upstream pressure – 2 connections									5			
Threaded gauge conn. left side (relative to flow direction) – upstream pressure – ISO 228 G 1/4"									4			
Threaded gauge conn. right side (relative to flow direction) – upstream pressure – ISO 228 G 1/4"									3			
Threaded gauge conn. left side (relative to flow direction) – upstream & downstream press. – 2 conn. – ISO 228 G 1/4"									1			
Threaded gauge conn. right side (relative to flow direction) – upstream & downstream press. – 2 conn. – ISO 228 G 1/4"									0			
Threaded gauge conn. both sides – upstream pressure – ISO 228 G 1/4"									2			
Threaded gauge conn. left side (relative to flow direction) – upstream pressure – 1/4" NPT									W			
Threaded gauge conn. right side (relative to flow direction) – upstream pressure – 1/4" NPT									Y			
Threaded gauge conn. left side (relative to flow direction) – upstream & downstream press. – 2 conn. – 1/4" NPT									U			
Threaded gauge conn. right side (relative to flow direction) – upstream & downstream press. – 2 conn. – 1/4" NPT									V			
Threaded gauge conn. both sides – upstream pressure – 1/4" NPT									Z			
Surface finish a)												
Standard surface finish									X			
Mirror mechanical polished external surfaces (SF1)									P			
Electropolished internal wetted parts (SF5)									E			
Special features												
None										X		
Degreased for oxygen										O		
Pipe connection												
Clamp ferrule ASME BPE											D	
Clamp ferrule DIN (DIN 32676-A)											F	
Clamp ferrule ISO (DIN 32676-B)											E	
Tube weld (ETO) according to ASME BPE											DI	
Tube weld (ETO) according to DIN 11866-A (DIN 11850-2)											FI	
Tube weld (ETO) according to DIN 11866-B (ISO 1127)											EI	
Size												
DN 32 (available with ISO connections only)												32
1 1/2" or DN 40												40
2" or DN 50 (not available with ISO connections)												50
Special construction / Additional options												
Full description or additional codes have to be added in case of non-standard combination												E

a) Consult TIS.GIA – General information ADCAPure – for further details and other surface finish options.