

## SANITARY SIGHT GLASSES SWS

### DESCRIPTION

The SWS sanitary sight glasses are designed to monitor liquid flow in any direction.

Sight glasses, also called flow indicators, are usually employed to detect either the presence or absence of fluid flow, turbulence, colour, etc. They are specially recommended for high purity applications.

### MAIN FEATURES

Compact design.  
Completely machined from bar stock materials, no castings or forgings are used on the standard version.  
Precision borosilicate glass mounted without stress.  
Excellent visualization.

### STANDARD SURFACE FINISH

Internal wetted parts:  $\leq 0,51 \mu\text{m Ra} - \text{SF1}$ .  
External:  $\leq 0,76 \mu\text{m Ra} - \text{SF3}$ .  
Other surface conditions see TIS.GIA – General information ADCAPure.  
Ultrasonic cleaning.

OPTIONS: Full view design.  
USE: Clean steam, water and other liquids and gases compatible with the construction.

AVAILABLE MODELS: SWS.

SIZES: 1/2" to 4".

CONNECTIONS: ASME BPE clamp ferrules.  
Others on request.

PACKAGING: Assembling and packaging in a clean room certified according to ISO 14644-1.  
The product is end capped and sealed with recyclable thermo-shrinkable plastic film, to avoid contamination.

INSTALLATION: In any position. See IMI – Installation and maintenance instructions.



CE MARKING – GROUP 2 (PED – European Directive)	
Size	Category
1/2" to 4"	SEP

LIMITING CONDITIONS *	
Maximum operating temperature – EPDM seals	150 °C
Maximum operating temperature – EPDM seals (steam and water) **	180 °C
Maximum operating temperature – PTFE seals	200 °C
Minimum operating temperature	-10 °C

\* Other limits on request. Maximum operating conditions may be limited by the equipment end connections due to normative restrictions.

\*\* High performance EPDM. Maximum operating temperature of 210 °C, for short periods of time.

**MAXIMUM OPERATING PRESSURE (bar)**

1/2"	3/4"	1"	1 1/2"	2"	2 1/2"	3"	4"
20	16	14	10	10	9	9	8

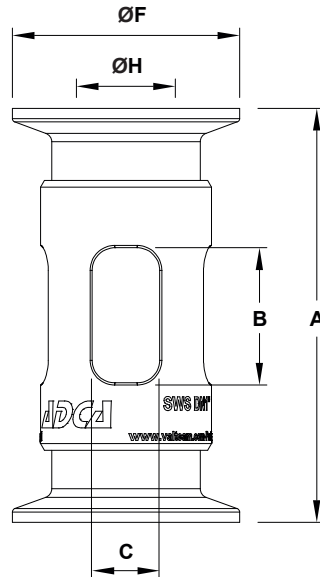

**DIMENSIONS (mm)**

SIZE	A	B	C	ØF	ØH	WEIGHT (kg)
1/2"	76	20	10	25	9,4	0,13
3/4"	92	30	10	25	15,8	0,23
1"	92	30	15	50,4	22,1	0,4
1 1/2"	105	32	24	50,4	34,8	0,58
2"	120	48	34	63,9	47,5	0,83
2 1/2"	151	55	40	77,4	60,2	1,35
3"	175	90	50	90,1	72,9	2,53
4"	200	110	60	118,9	97,4	3,81

**MATERIALS**

POS. N°	DESIGNATION	MATERIAL
1	Valve body	AISI 316L / 1.4404
2	* Glass	Borosilicate
3	Connection ends	AISI 316L / 1.4404
4	* O-ring	High performance EPDM
5	* O-ring	** High performance EPDM; PTFE

\* Available spare parts. \*\* Others on request.

Remarks: FDA / USP Class VI seals certificate on request.

All valves have a serial number. In case of non-standard valves, this number must be supplied if spare parts are ordered.

