

LINEAR ELECTRIC ACTUATORS EL (1,2 kN to 25 kN)

DESCRIPTION

The EL series linear electric actuators are designed for operation of control valves in modulating and on/off services in process engineering and industrial applications. The self-locking stem nut is driven by an electric motor via a gearing.

Load-dependent switches and/or mechanical limit switches define the stops for the end positions.

MAIN FEATURES

Modular retrofittable design.

24 V AC, 115 V AC, 230 V AC, 400 V AC 50/60 Hz and 24 V DC supply voltages.

Manual operation with disengagement of the actuator motor.

IP 65 (EL12 IP 43) protection.

Valve protection against excessive force due to load-dependent seating.

Mounting to valves made via yoke or mounting flange DIN 3358, enabling easy connection to all types of valves. Standard version is suitable for ADCATrol valves.

Defined closing force in the end positions leading to tight valve shut-off.

Stall proof synchronous motors (or brake motors for higher positioning forces) ensure highest positioning accuracy.

Mechanical stroke indication via anti-rotation bar.

Exact, backlash-free measurement of actual valve stroke by direct coupling to the valve stem.

Universally usable actuators due to control via 3-point-step controllers, analogue input signals (0 to 10 V, 0(4) to 20 mA), or fieldbus systems.

Limit switches are easily adjustable for stroke limitation or as signal for intermediate positions.

OPTIONS AND

ACCESSORIES: Electronic positioner.
Additional limit switches.
Potentiometers e.g. for 3-point-step control in closed loop.
0(4) to 20 mA electronic position feedback units.
Heating resistor.
Special coatings and finishes for aggressive environments.

USE: Actuation of ADCATrol control valves, or others on request.

AVAILABLE

MODELS: EL12, EL20, EL45, EL80, EL120 and EL250.



TECHNICAL DATA

MODEL	EL12	EL20	EL45	EL45.1	EL45.2
Positioning force (kN)	1,2	2,0	4,5	4,5	4,5
Positioning speed (mm/min / mm/s) a)	8 / 0,14	15 / 0,25	17 / 0,28	25 / 0,4	50 / 0,8
Power consumption – 230 V (W)	4	6,6	28	28	32
Nominal current – 230 V (A)	0,017	0,029	0,135	0,135	0,160
Type of motor b)	Syn	Syn	Asyn	Asyn	Asyn
Motor protection c)	B				
Maximum stroke (mm)	35	50 (75 on request)			
Supply voltages d)	24 V / 115 V / 230 V / 400 V 50/60 Hz, 24 V DC				
Type of duty acc. to IEC 34-1	S1 – 100%		S4 – 30% c.d.f. 600 c/h		
Cable entry	3 x M16 x 1,5	2 x M16 x 1,5 and 1 dummy plug M16 x 1,5			
Electrical connection	Inside terminal board, terminal configuration according to electric connection wiring diagram				
Switch off in end position	2 load dependent switches, max. 250 V AC, rating for resistive load: max. 5 A, for inductive load: max. 3 A				
Mounting position	As desired, except downward position				
Ambient temperature	- 20 °C to 60 °C				
Lubricant for gearing	Klüber Mickrolube GL 261 grease				
Position indicator	By anti-rotation bar				
Manual adjustment	Crank handle	Side handwheel			
Enclosure protection acc. to EN 60529	IP 43	IP 65			
Trapezoidal thread	Tr 8 x 1,5	Tr 14 x 3			
Connection type	EN ISO 5210 F05				

MODEL	EL80	EL80.1	EL80.2	EL120	EL120.1	EL120.2
Positioning force (kN)	8,0			12		
Positioning speed (mm/min / mm/s) a)	13,5 / 0,2	25 / 0,4	50 / 0,8	13,5 / 0,2	25 / 0,4	50 / 0,8
Power consumption – 230 V (W)	25	34	152	25	34	152
Nominal current – 230 V (A)	0,11	0,15	0,78	0,11	0,15	0,78
Type of motor b)	Syn	Syn	Asyn	Syn	Syn	Asyn
Motor protection c)	B	B	T	B	B	T
Maximum stroke (mm)	80					
Supply voltages d)	24 V / 115 V / 230 V / 400 V 50/60 Hz, 24 V DC					
Type of duty acc. to IEC 34-1	S4 – 30% c.d.f. 600 c/h					
Cable entry	2 x M16 x 1,5 and 1 dummy plug M16 x 1,5					
Electrical connection	Inside terminal board, terminal configuration according to electric connection wiring diagram					
Switch off in end position	2 load dependent switches, max. 250 V AC, rating for resistive load: max. 5 A, for inductive load: max. 3 A					
Mounting position	As desired, except downward position					
Ambient temperature	- 20 °C to 60 °C					
Lubricant for gearing	Klüber Mickrolube GL 261 grease					
Position indicator	By anti-rotation bar					
Manual adjustment	Side handwheel					
Enclosure protection acc. to EN 60529	IP65					
Trapezoidal thread	Tr 20 x 3					
Connection type	DIN 3210 G0					

MODEL	EL 250.1	EL 250.2
Positioning force (kN)	25	
Positioning speed (mm/min / mm/s) a)	25 / 0,4	50 / 0,8
Power consumption – 230 V (W)	157	218
Nominal current – 230 V (A)	0,73	1,0
Type of motor b)	Asyn	
Motor protection c)	T	
Maximum stroke (mm)	100	
Supply voltages d)	24 V / 115 V / 230 V / 400 V 50/60 Hz, 24 V DC	
Type of duty acc. to IEC 34-1	S4 – 30% c.d.f. 600 c/h	
Cable entry	2 x M20 x 1,5 and 1 dummy plug M16 x 1,5	
Electrical connection	Inside terminal board, terminal configuration according to electric connection wiring diagram	
Switch off in end position	2 load dependent switches, max. 250 V AC, rating for resistive load: max. 5 A, for inductive load: max. 3 A	
Mounting position	As desired, except downward position	
Ambient temperature	- 20 °C to 60 °C	
Lubricant for gearing	Klüber Mickrolube GL 261 grease	
Position indicator	By anti-rotation bar	
Manual adjustment	Side handwheel	
Enclosure protection acc. to EN 60529	IP 65	
Trapezoidal thread	Tr 26 x 5	
Connection type	DIN 3210 G0	

a) At 60 Hz, the positioning speed and input power increase by 20%.

b) Syn – synchronous motor; Asyn – asynchronous motor.

c) B – stallproof motor; T – thermoswitch for temperature monitoring.

d) Other supply voltages on request.

OPTIONS AND ACCESSORIES	
DESIGNATION	DESCRIPTION
FG	Switching and signaling unit (teletransmitter assembly). The FG unit is the base necessary for the assembly of all remaining options.
WE	Additional limit switches for signaling end positions or intermediate positions, freely adjustable, max. 250 V AC, rating for resistive load max. 5 A, for inductive load max. 3 A, max. 2 switches for EL20 and EL45, max. 4 switches for EL80 and EL120.
WE-G	Additional limit switches for signaling end positions or intermediate positions, freely adjustable, with gold-plated contacts for low voltage, max. 30 V AC, rating for resistive load max. 0,1 A, max. 2 switches for EL20 and EL45, max. 4 switches for EL80 and EL120.
POT	Potentiometer 100/130/200/500/1000/5000 Ohms or 10 kOhms Linearity error £ 0.5 %, max. 1.5 W, contact current 30 mA max. 2 pieces
ESR100	Electronic position feedback 2/3-wire unit. Remark: Includes POT 5000 Ohms. Inductive travel measuring, output 0(4) to 20 mA. Connection 24 V DC (not possible for EL12).
PEL100	Electronic positioner for actuator control. Remark: Includes FG teletransmitter assembly and POT 1000 Ohms. Input 0 to 10 V, 0(4) to 20, output 0 to 10 V, 0(4) to 20 mA. Supply voltage 24, 115, 230 V 50/60 Hz.
PEL200	Intelligent electronic positioner for actuator control. Remark: Includes FG teletransmitter assembly and POT 1000 Ohms. Input 0 to 10 V, 0(4) to 20 mA, output 0 to 10 V, 0(4) to 20 mA. Supply voltage 24, 115, 230 V 50/60 Hz.
HZ/WP	Heating resistor with thermoswitch against moisture with automatic temperature regulation, max. 15 Watts Supply voltage 24, 115, 230 V 50/60 Hz
STALA / FLA	Yoke for adaptation to valves. Refer to dimension sheet.
ZFLA	Mounting flange with central attachment Mxx. Refer to dimensions sheet (thrust rod must be secured against revolving).
KS	Compact plug 10/24 poles with additional housing at actuator voltages ≤ 500 V.
LA-TR	Special finish coating for use in the tropics ("tropics coating").
A-IP65	Version IP 65: with bellows at thrust rod and metal cover with seal (for EL12)
A-FAB	Version with bellows at thrust rod (for EL20, 45, 80 and 120).

ELECTRICAL CONNECTIONS				
3 ~ ASYNCHRONOUS MOTOR WITH BRAKE AND THERMOSWITCH	1 ~ ASYNCHRONOUS MOTOR WITH BRAKE AND THERMOSWITCH	SYNCHRONOUS MOTOR WITH THERMOSWITCH	SYNCHRO- NOUS MOTOR	BASIC WIRING DIAGRAM INCLUDING OPTIONS
				Switch-off in both end positions is made via two load-dependant switches, e.g. two-way valves with upper stroke limit and three-way mixing valves.
				Switch-off in the lower end position is made via a load-dependent switch and on the upper end position via a mechanical limit switch, e.g. two-way valves without upper stroke limit.
				Control of three-phase actuators with thermoswitch. Switch off in end position is made via two load-dependant switches to control e.g. three-way mixing valves. Remarks: For motors without thermoswitch, the wiring to terminal 4 and 5 is not applicable.
				Control of three-phase actuators with thermoswitch. Switch off in end position is made via a load-dependent switch and a mechanical limit switch to control e.g. two-way valves without upper stop. Remarks: For motors without thermoswitch, the wiring to terminal 4 and 5 is not applicable.

WE – Limit switch

HZ – Heater with thermoswitch

POT – Potentiometer

ESR – Electronic position feedback

PEL – Electronic positioner

WSE – External reversing contactor unit

REG – Process controller

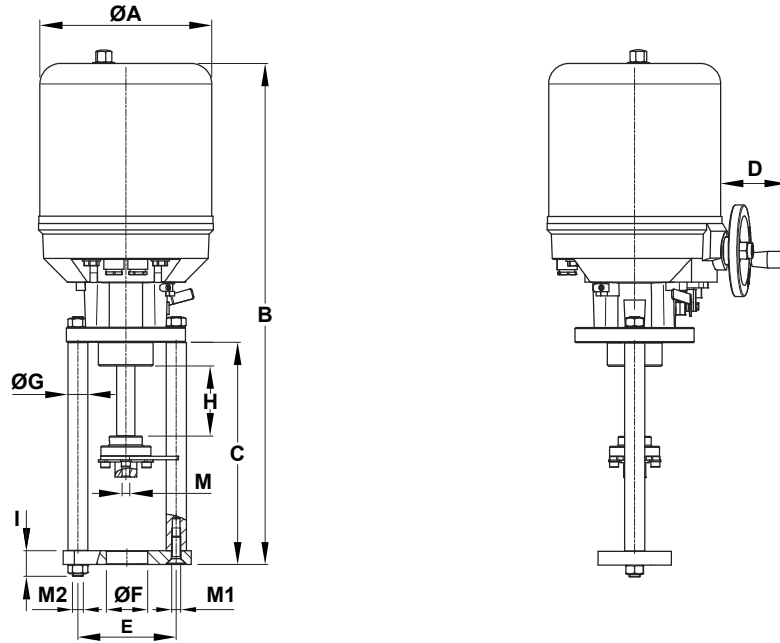

DIMENSIONS (mm)

MODEL	ØA	B	C	D	E	ØF	ØG	H	I	M *	M1	M2	WGT. (kg)
EL12	129	315	175	–	100	40	16	35	–	M10	M10	–	2,1
EL20 / EL45	148	474	205	42	100 / 110	40 / 45	22	50	41	M10 / M16	M10	M16	8
EL80 / EL120	188	572	245	70	100 / 110	40 / 45	22	80	41	M10 / M16	M10	M16	13
EL250	216	668	260	70	125	45 / 65	22	100	41	M16 / M20	–	M16	19

* Depending on valve stem thread. Can be course or fine thread.

Remark: Stem coupling, yoke dimensions and design may vary depending on the ADCATrol control valve model. Refer to its corresponding information sheet or consult the manufacturer.



ORDERING CODES EL								
Group designation	E	12	1	X	X	X	A1	
EL series linear electric actuator	E							
Actuator model								
EL12		12						
EL20		20						
EL45		40						
EL45.1		41						
EL45.2		42						
EL80		60						
EL80.1		61						
EL80.2		62						
EL120		70						
EL120.1		71						
EL120.2		72						
EL250		80						
EL250.1		81						
EL250.2		82						
Supply voltage								
230 V AC 50/60 Hz			1					
115 V AC 50/60 Hz			2					
24 V AC 50/60 Hz			3					
24 V DC			4					
400 V AC 3~ 50/60 Hz			5					
Electronic positioner and teletransmitter assembly								
Without FG teletransmitter assembly and electronic positioner				X				
FG teletransmitter assembly				T				
PEL100 electronic positioner				P				
PEL200 intelligent electronic positioner				I				
Limit switches								
Without additional limit switches					X			
One additional WE limit switch					1			
Two additional WE limit switches					2			
Position feedback unit								
Without position feedback unit						X		
ESR100 electronic position feedback unit						F		
Yoke design and coupling								
ADCATrol V16/2 and V25/2 series (DN 15 to DN 50 – 1/2" to 2")							A1	
ADCAPure V926H, V926A (1/2" to 21/2") and V928 series (DN 15 to DN 50) a)							A3	
ADCATrol V16/2 series (DN 65 to DN 100 – 3" to 4")							B1	
ADCATrol V25/2 series (DN 65 to DN 100 – 3" to 4")							B2	
ADCAPure V926H (3" and 4") and V928 series (DN 65 to DN 100) a)							B3	
ADCATrol V25/2 series (DN 125 to DN 150 – 5" to 6")							C2	
ADCATrol V25/2 series (DN 200 – 8")							D2	
Other ADCATol valves b)							XX	
Special versions / Extras								
Full description or additional codes have to be added in case of a non-standard combination								E

a) Require an additional WE limit switch for switching off in the upper end position. Except V928MV, V928MH and V928D.

b) Exact model and size must be specified – consult the manufacturer.

Remark: Options and accessories not mentioned in the ordering codes table must be requested separately, e.g.: E.201XXXA1 fitted with HZ/WP heating resistor with thermoswitch.

How to size: For selection of suitable actuator to use with ADCATrol control valves, consult IS PV15.00 – Maximum permissible pressure drops for ADCATrol control valves – or consult the manufacturer.